

Ruijie Reyee RG-NBS3100-48GT4SFP-P Switch

Hardware Installation and Reference Guide



Document Version: V1.0

Date: November 29, 2022

Copyright © 2022 Ruijie Networks

Copyright Statement

Ruijie Networks©2022

All rights are reserved in this document and this statement.

Any reproduction, excerpt, backup, modification, transmission, translation or commercial use of this document or any portion of this document, in any form or by any means, without the prior written consent of Ruijie Networks is prohibited.

Trademarks including , ,  are owned by Ruijie Networks.

All other trademarks or registered trademarks mentioned in this document are owned by their respective owners.

Exemption Statement

The products, services or features you purchase are subject to commercial contracts and terms. Some or all of the products, services or features described in this document may not be within the scope of your purchase or use. Unless otherwise agreed in the contract, Ruijie Networks does not make any express or implied statement or guarantee for the content of this document.

Due to product version upgrades or other reasons, the content of this document will be updated from time to time. Ruijie Networks reserves the right to modify the content of the document without any notice or prompt.

This manual is for reference only. Ruijie Networks endeavors to ensure content accuracy and will not shoulder any responsibility for losses and damages caused due to content omissions, inaccuracies or errors.

Preface

Intended Audience

This document is intended for:

- Network engineers
- Technical support and servicing engineers
- Network administrators

Technical Support

- The official website of Ruijie Reye: <https://www.ruijienetworks.com/products/rejee>
- Technical Support Website: <https://www.ruijienetworks.com/support>
- Case Portal: <https://caseportal.ruijienetworks.com>
- Community: <https://community.ruijienetworks.com>
- Technical Support Email: service_rj@ruijienetworks.com

Conventions

1. Signs

The signs used in this document are described as below:

Danger

An alert that calls attention to safety operation instructions that if not understood or followed when operating the device can result in physical injury.

Warning

An alert that calls attention to important rules and information that if not understood or followed can result in data loss or equipment damage.

Caution

An alert that calls attention to essential information that if not understood or followed can result in function failure or performance degradation.

Note

An alert that contains additional or supplementary information that if not understood or followed will not lead to serious consequences.

Specification

An alert that contains a description of product or version support.

2. Note

This manual provides the device installation steps, hardware troubleshooting, module technical specifications, and specifications and usage guidelines for cables and connectors. It is intended for the users who have some experience in installing and maintaining network hardware. At the same time, it is assumed that the users are already familiar with the related terms and concepts.

Contents

Preface	I
1 Product Overview	4
1.1 RG-NBS3100-48GT4SFP-P	4
1.2 Package Contents.....	4
1.3 Appearance.....	5
1.3.1 Front Panel.....	5
1.3.2 Rear Panel	6
1.3.3 Ventilation.....	7
1.4 Technical Specifications	7
2 Preparing for Installation	9
2.1 Safety Precautions.....	9
2.1.1 General Safety Precautions.....	9
2.1.2 Handling Safety.....	9
2.1.3 Electric Safety	9
2.1.4 Static Electricity.....	10
2.1.5 Laser Safety	11
2.2 Installation Environment Requirements.....	11
2.2.1 Bearing Requirements	11
2.2.2 Ventilation Requirements.....	11
2.2.3 Space Requirements	11
2.2.4 Temperature and Humidity Requirements	11
2.2.5 Cleanliness Requirements.....	12
2.2.6 Grounding Requirements.....	13

2.2.7 Lightning Protection Requirements	13
2.2.8 EMI Requirements	14
2.2.9 Installation Site Requirements	14
2.3 Rack Requirements	14
2.4 Tools	15
3 Installing the Switch	16
3.1 Installation Flowchart	16
3.2 Before You Begin	17
3.3 Installing the Switch	17
3.3.1 Installing the Switch in a Rack	17
3.3.2 Installing the Switch on a Workbench	19
3.4 Connecting the Switch to Earth Ground	20
3.5 Connecting Cables	20
3.6 Bundling Cables	21
3.7 Verifying Installation	21
4 Verifying Operating Status	22
4.1 Setting up Configuration Environment	22
4.2 Powering on the Switch	22
4.2.1 Checklist Before Power-On	22
4.2.2 Checklist After Power-On	22
5 Common Troubleshooting	24
5.1 Troubleshooting Flowchart	24
5.2 Common Faults	24
6 Appendix	26

6.1 Connectors and Media.....	26
6.2 Mini-GBIC Modules.....	28
6.3 Lightning Protection	31
6.4 Cabling Recommendations.....	34
6.4.1 Requirement for the Minimum Bend Radius of an Ethernet Cable	34
6.4.2 Requirement for the Minimum Bend Radius of a Fiber-Optic Cable.....	34
6.4.3 Precautions for Bundling up Cables	34
6.5 Site Selection	38

1 Product Overview

RG-NBS3100-48GT4SFP-P is a new generation Layer 2 Ethernet switch developed by Ruijie Networks. The switch provides GE Ethernet ports and GE SFP ports and features high performance, high reliability and multi-service integration. It adopts an efficient hardware architecture design for larger MAC address table capacity, higher hardware performance and more convenient experience.

The switch has 48 10/100/1000Base-T PoE/PoE+ ports and four 1000 Mbps SFP ports with a PoE consumption of 370 W. It supports App and cloud-based management.

Model	10/100/1000Base-T Ethernet port	1000 Mbps SFP port	Power supply
RG-NBS3100-48GT4SFP-P	48	4	Fixed single power supply

1.1 RG-NBS3100-48GT4SFP-P

The RG-NBS3100-48GT4SFP-P switch provides 48 10/100/1000Base-T RJ45 Ethernet ports and four 1000 Mbps SFP ports on the front panel, and an AC power input plug on the rear panel. The switch supports routing, Rapid Spanning Tree Protocol (RSTP) and link aggregation. It can be managed through Eweb, Ruijie Cloud and App.

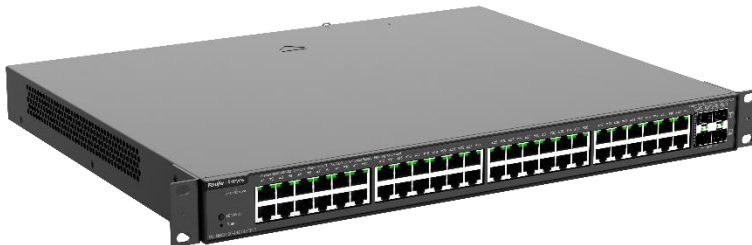

1.2 Package Contents

Table 1-1 Package Contents

Item	Quantity
RG-NBS3100-48GT4SFP-P Switch	1
Mounting Bracket	2
Rubber Pad	4
M4 x 8 mm Screw	8

Item	Quantity
Management Software	1
Grounding Cable	1
Power Cord (1.8 m/5.91 ft)	1
Power Cord Retention Clip	1
User Manual	1
Warranty Card	1

Note

The above is the general Packet Contents. The actual delivery is subject to the order contract. And please check your goods carefully against the order contract. If you have any questions, please contact the distributor.

1.3 Appearance

1.3.1 Front Panel

Figure 1-1 Front Panel



Table 1-2 Ports and Buttons on the Front Panel

ID	Item	Description
1	Reset Button	Press and hold for no more than two seconds: Restart the switch Press and hold for two to five seconds: No action Press and hold for over five seconds: Fetch logs, reset username and password, and restart the device. After the device restarts, select whether to restore factory settings on Eweb or App.
2	LED Mode Switchover Button	Switch over the LED mode

3	System Status LED	Off: The switch is not powered on. Fast blinking (0.5 Hz): The switch is operating properly but not connected to Ruijie Cloud, Fast blinking (10 Hz): The switch is upgrading or restarting. Solid green: The switch is operating properly and connected to Ruijie Cloud.
4	Ethernet Port Status LED	Off: The LED indicates the Link/ACK status. Solid green: The LED indicates the PoE status.
5	Ethernet Port	10/100/1000Base-T Ethernet Port
6	SFP port	1000 Mbps SFP Port
7	SFP Port Status LED	Blinking green: The port is receiving or sending data. Solid green: The port is connected but not receiving or sending data. Off: The port is not connected.
8	Nameplate	Nameplate on the bottom of the device.

1.3.2 Rear Panel

Figure 1-2 Rear Panel



Table 1-3 Ports and Buttons on the Rear panel

ID	Item	Description
1	AC Power Input Plug	Connect to an external AC power supply.
2	Power Cord Retention Clip	Secure the power cord.
3	Grounding Screw	Secure the grounding lug to ensure connection between the chassis and earth ground.

1.3.3 Ventilation

The RG-NBS3100-48GT4SFP-P switch adopts the side-to-rear airflow design to ensure that the switch works properly in the specified environment. Maintain a minimum clearance of 100 mm (3.94 in.) around the switch to ensure proper ventilation. You are advised to dust the switch at an interval of three months to avoid blocking the ventilation openings.

Figure 1-3 Airflow Direction

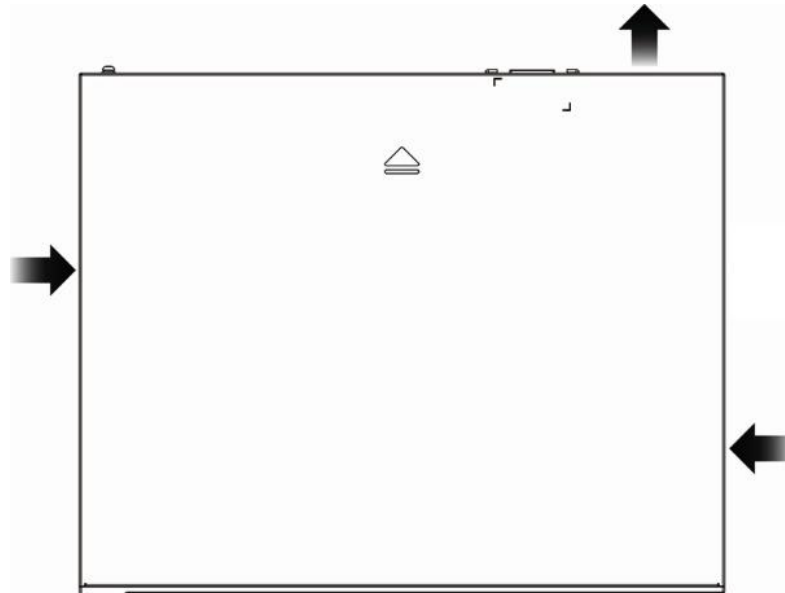

Note

Maintain a minimum clearance of 1 RU (44.45 mm) between the switch and its neighboring device to ensure proper ventilation.

1.4 Technical Specifications

Table 1-4 Specifications

Model	RG-NBS3100-48GT4SFP-P
CPU	1 GHz dual-core CPU
Flash Memory	256 MB
SDRAM	DDRIII 512 MB
Port	48 10/100/1000Base-T Ethernet ports with auto negotiation and crossover detection (auto MDI/MDIX crossover) Ports 1 to 48 are PoE-capable Four 1000 Mbps SFP ports

LED	System status LED and Link/ACT status LED
Maximum Power Consumption	Overall maximum PoE/PoE+ output power: 370 W Overall maximum output power: 448 W
PoE	IEEE802.af and 802.3at compliant Maximum PoE output power: 370 W Maximum PoE output power per port: 30 W
EEE Function	Supported
Temperature Alarming	Not supported
Fans	2 (automatic speed adjustment)
Power Supplies	AC input: Rated voltage range: 100 V AC to 240 V AC Maximum voltage range: 90 V AC to 264 V AC Frequency: 50 Hz to 60 Hz Rated current: 7 A Working current: ≤ 2.5 A
Leakage Current to Ground	≤ 3.5 mA
Operating Altitude	0 m to 5000 m (0 to 16404 ft)
Operating Temperature	0°C to 50°C (32°F to 122°F)
Storage Temperature	-40°C to 70°C (-40°F to 158°F)
Operating Humidity	10% to 90% RH (non-condensing)
Storage Humidity	5% to 90% RH (non-condensing)
Lightning Protection (Port Surge Protection)	6 kV
Certification	CE
Dimensions (W x D x H)	440 mm x 357.6 mm x 43.6 mm (17.32 in. x 14.08 in. x 1.72 in.)
Weight	5.62 kg (12.39 lbs, including the package)

 **Warning**

- Operation of this equipment in a residential environment could cause radio interference.
- This equipment is not suitable for use in locations where children are likely to be present.

2 Preparing for Installation

2.1 Safety Precautions

Note

- To avoid personal injury and device damage, carefully read the safety precautions before you install the switch.
 - The following safety precautions may not cover all possible dangers.
-

2.1.1 General Safety Precautions

- Install the switch in a standard 19-inch rack.
- Cut off all power supplies and unplug all power cords before mounting the switch in a rack or removing the switch from a rack.
- Do not place the switch in a wet position, and keep the switch away from liquid. Keep the chassis clean and dust-free.
- Install the switch in a position far away from heat sources.
- Ensure that the rack and power distribution system are properly grounded.
- Do not place the switch in walking areas.
- During installation and maintenance, do not wear loose clothes, ornaments, or any other things that may be hooked by the chassis.
- Keep tools and components away from walking areas.

2.1.2 Handling Safety

- Prevent the switch from being frequently handled.
- Cut off all power supplies and unplug all power cords before moving or handling the device.
- Keep balance and prevent personal injuries when handling the switch.

2.1.3 Electric Safety

Warning

- Any nonstandard and inaccurate operation can cause an accident such as fire or electrical attack, thus causing severe damages to human bodies and the switch.
 - Direct or indirect touch through a wet object on high-voltage and mains supply can bring a fatal danger.
-

- Observe local regulations and specifications during electric operations. Only personnel with qualifications can perform such operations.
- Check whether there are potential risks in the work area. For example, check whether the power supply is grounded, whether the grounding is reliable, and whether the ground is wet.

- Find out the position of the indoor emergency power switch before installation. Cut off the power switch in the case of accidents.
- Make sure that the switch is powered off when you cut off the power supply.
- Equip the power supply system with a leakage protector (also referred to as “leakage current switch” or “leakage current breaker”) to automate the power cut-off in the case of power leakage or shock. When selecting the leakage protector, observe the following rule:
 - The rated leakage action current of each leakage protector is greater than twice of the theoretical maximum leakage current of all the power supplies in the system.

For example, if a system is equipped with 16 identical power supplies, the leakage current of each power supply is at most 3.5 mA, and the leakage current of the system totals 56 mA (maximum theoretical value). A leakage protector with 30 mA rated action current supports less than nine power supplies (that is, Action current of the leakage protector/2/Maximum leakage current of each power supply = $30/2/3.5 \approx 4.28$). In other words, the leakage protector with a rated action current of 30 mA supports up to four power supplies. In this case, the 16 power supplies in the system require at least four leakage protectors with a rated action current of 30 mA and each leakage protector supports four power supplies.

If power supplies in a system differ in models, the rated leakage action current of each leakage protector divided by two is greater than the sum of maximum leakage currents of all the power supplies.

- The rated leakage non-action current of a leakage protector shall be 50% of the leakage action current. If the non-action current value is too small, the high sensitivity level may cause the circuit to break, causing power cut-off and service interruption even if the leakage current value is normal.

Take a leakage protector with a rated action current of 30 mA as an example. The rated leakage non-action current shall be 15 mA. When the leakage current is less than 15mA, the protector shall not act.

 **Caution**

- To guarantee personal safety, the rated leakage action current of each leakage protector in the system must be equal to or less than 30 mA (human body safety current is 30 mA). When twice of the total leakage current of the system is greater than 30 mA, the system must be equipped with two or more leakage protectors.
- The leakage current values vary with products. For the leakage current value of each product model, see the technical specifications in [Section 1.4 Technical Specifications](#).

2.1.4 Static Electricity

- Ensure that the grounding screw on the rear panel of the device is tightened. Ensure that the AC power socket is a single-phase three-core power socket with protective earthing conductors (PE).
- Keep the indoor installation environment clean and free of dust.
- Maintain appropriate humidity conditions.

Before installing the various pluggable modules, please wear an anti-static wrist strap and make sure that it is well grounded.

2.1.5 Laser Safety

The RG-NBS3100 switch supports various types of optical transceivers available in the market, and these optical transceiver are Class I laser products. Improper use of an optical transceiver may cause damage. Therefore, pay attention to the following:

- When an optical transceiver is working, ensure that its port has been connected with an optical fiber or covered by a dust cap to keep out dust and prevent it from burning your eyes.
- When an optical transceiver is working, do not look into its port after removing the optical fiber. Otherwise, your eyes may be hurt.

! Warning

Do not approach or look into any optical port under any circumstances. This may cause permanent damage to your eyes.

2.2 Installation Environment Requirements

Install the switch indoors to ensure its normal operation and prolonged service life. The installation site must meet the following requirements.

2.2.1 Bearing Requirements

Evaluate the weight of the switch and its accessories (such as the rack and cables) and ensure that the ground of the installation site observes the requirements.

2.2.2 Ventilation Requirements

Maintain a minimum clearance of 100 mm (3.94 in.) around the switch for air circulation and ventilation. After various cables are connected, bind the cables or place them in the cable management bracket to avoid blocking air inlets. You are advised to dust the switch at an interval of three months to avoid blocking the ventilation openings.

2.2.3 Space Requirements

To have sufficient room for chassis handling and module swapping, you are advised to maintain an indoor pathway of at least 800 mm (31.50 in.) wide.

Do not install the device against the wall. Instead, maintain a minimum clearance of 400 mm (15.75 in.) around the switch for proper ventilation.

2.2.4 Temperature and Humidity Requirements

To ensure the normal operation and prolonged service life of the switch, maintain an appropriate temperature and humidity in the machine room. Working in an environment with too high or too low temperature and humidity for a long period may damage the switch.

- In an environment with high relative humidity, the insulating material may have poor insulation or even leak electricity.
- In an environment with low relative humidity, the insulating strip may dry and shrink, loosening screws.
- In a dry environment, the internal circuits are prone to static electricity.

- A high temperature can accelerate the aging process of insulation materials, greatly reducing the reliability of the switch and severely affecting its service life.

Note

The working temperature and humidity of the switch are measured at the point that is 1.5 m (59.06 in.) above the floor and 0.4 m (15.75 in.) before the device when there is no protective plate in front or at the back of the switch.

2.2.5 Cleanliness Requirements

Dust poses a major threat to the switch. The indoor dust takes on a positive or negative static electric charge when falling on the switch, causing poor contact of the metallic joint. Such electrostatic adhesion may occur more easily when the relative humidity is low, not only affecting the service life of the switch, but also causing communication faults. The following table describes the requirements for the dust content and granularity in the machine room.

Table 2-1 Requirements for Dust

Dust	Unit	Maximum Quantity
Dust particles (diameter $\geq 0.5 \mu\text{m}$)	Particles/ m^3	3.5×10^6
Dust particles (diameter $\geq 5 \mu\text{m}$)	Particles/ m^3	3×10^4

Apart from dust, the salt, acid, and sulfide in the air in the machine room must meet strict requirements. These harmful substances will accelerate metal corrosion and component aging. Therefore, the machine room should be properly protected against the intrusion of harmful gases, such as sulfur dioxide, hydrogen sulfide, nitrogen dioxide, and chlorine gas. The following table lists limit values for harmful gases.

Table 2-2 Requirements for Gases

Gas	Average (mg/m^3)	Maximum (mg/m^3)
Sulfur dioxide (SO_2)	0.3	1.0
Hydrogen sulfide (H_2S)	0.1	0.5
Nitrogen dioxide (NO_2)	0.5	1.0
Chlorine gas (Cl_2)	0.1	0.3

Note

Average refers to the average value of harmful gases measured in one week. **Maximum** refers to the upper limit of harmful gases measured in one week, and the maximum value cannot last for more than 30 minutes every day.

2.2.6 Grounding Requirements

A proper grounding system is the basis for stable and reliable running. It is indispensable for preventing lightning strikes and interference. Carefully check the grounding conditions at the installation site according to the grounding specifications, and complete grounding properly based on the actual situation.

● Secure Grounding

Ensure that the switch is securely grounded using a yellow/green grounding cable when the switch uses the AC power supply. Otherwise, electric shock may occur when the insulation resistance between the power supply inside the switch and the chassis becomes small.

Caution

- The building should provide a protective ground connection to ensure that the device is connected to a protective earth.
- The O&M personnel should check whether the AC socket is reliably connected to the protective ground of the building. If not, the O&M personnel should use a protective earth conductor from the AC outlet protective earth terminal to the building protective earth.
- The power socket should be installed near the device and easily accessible.
- During the device installation, the ground connection must always be made first and disconnected last.
- The cross-sectional area of the protective grounding cable should be at least 0.75 mm² (18 AWG).
- Install the switch by using 3-core power cords, with a minimum cross-sectional area of 0.75 mm² or 18 AWG per pin.

● Lightning Grounding

The lightning protection system of facilities is standalone, and is composed of a lightning rod, a down conductor, and a connector connected to the grounding system. The grounding system is usually used for power reference grounding and safety grounding of the rack. Lightning grounding is required only for facilities and is not required for the switch.

Note

For lightning protection, please see [Section 6.3 Lightning Protection](#).

● EMC Grounding

Grounding required for electromagnetic compatibility includes shielded grounding, filter grounding, noise and interference suppression, and level reference. The resistance of the grounding cable should be smaller than 1 ohm.

2.2.7 Lightning Protection Requirements

- Ensure that the neutral point of the AC power socket is in good contact with the ground.
- You are advised to install a power lightning arrester in front of the power input end to enhance the lightning prevention for the power supply.
- When an AC power cord is introduced from outdoors and directly connected to the power port of the switch, the AC power port must be connected to an external lightning resistance socket to protect the switch against lightning strokes. The lightning resistance socket is used as follows: Connect the mains AC power cord to

the lightning resistance socket and then connect the switch to the lightning resistance socket. This prevents the current of high-voltage lightning from directly passing through the switch along the mains cable.

Note

- Lightning resistance sockets are customer-supplied.
-

2.2.8 EMI Requirements

All interference sources, either from outside or inside of the device or application system, affect the device by capacitive coupling, inductive coupling, or electromagnetic waves. Electromagnetic interference (EMI) occurs due to electromagnetic radiation or conduction, depending on the transmission path. When the energy, often RF energy, from a component arrives at a sensitive component through the space, the energy is known as radiated interference. The interference source can be both a part of the interfered system and a completely electrically isolated unit. Conduction interference occurs when interference is transferred from one unit to another unit through cables, which are usually electromagnetic wires or signal cables connected between the source and the sensor. Conducted interference often affects the power supply of the equipment, but can be controlled by a filter. Radiated interference may affect any signal path in the devices, and is difficult to shield.

- Take interference prevention measures for the power supply system.
- Keep the switch far away from the lightning protection and grounding system of the power device.
- Keep the switch far away from high-frequency current devices such as high-power radio transmitting station and radar launcher.
- Take electromagnetic shielding measures when necessary.

2.2.9 Installation Site Requirements

Regardless of whether the device is installed in a rack or on a workbench, observe the following conditions:

- Maintain a proper clearance around the air intakes and outlets for heat dissipation.
- The switch is equipped with fans to draw air from side to rear. Maintain a minimum clearance of 150 mm (5.91 in.) around the ventilation openings for heat dissipation. You are advised to install the switch in a standard 19-inch rack. Or, place the device on a clean workbench. In hot areas, air-conditioning is recommended.
- The installation site has good cooling and ventilation.
- The installation site is sturdy enough to support the weight of the switch and its accessories.

The installation site is properly grounded.

2.3 Rack Requirements

The RG-NBS3100 switch meets the EIA standard and can be installed in a 19-inch rack. If you want to install the switch in a rack, make sure that the rack observes the following requirements:

- (1) Use a four-post 19-inch cabinet.
- (2) The left and right square hole rack posts are 465 mm (18.31 in.) apart.

Figure 2-1 19-Inch Rack

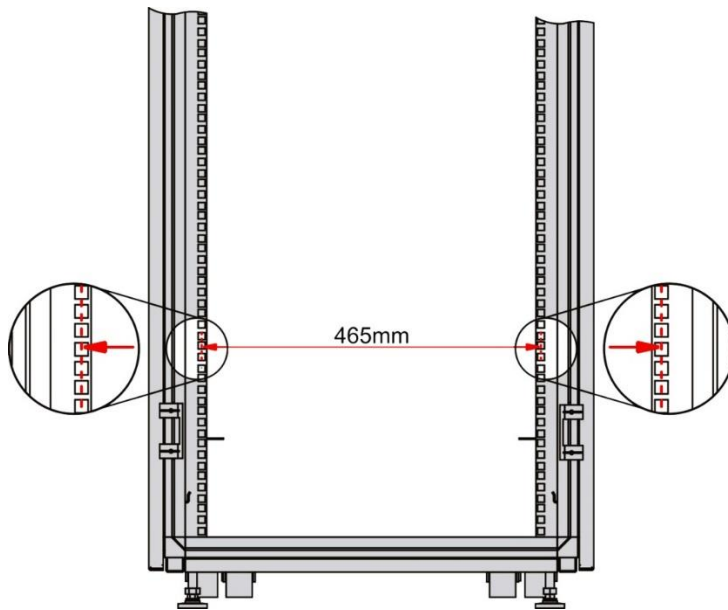

- (3) The square hole rack post is at least 180 mm (7.09 in.) from the front door, and the front door is at most 25 mm (0.98 in.) thick. This ensures an available clearance of at least 155 mm (6.10 in.). The rack depth, the distance between front and rear doors, is at least 1000 mm (39.37 in.).
- (4) The guide rails can bear the weight of the switch and its accessories.
- (5) The rack has a reliable grounding lug for the chassis to connect to earth ground.

The rack has a good ventilation system. The open area of front and rear doors is greater than 50%.

2.4 Tools

Table 2-3 Tools

Common Tools	Phillips screwdriver, power cords, Ethernet cables, fastening bolts, diagonal plier and cable ties
Special Tools	Anti-static wrist strap, wire stripper, crimping plier, crystal connector crimping plier, and wire cutter
Meters	Multimeter
Relevant Devices	PC, display, and keyboard

Note

The RG-NBS3100 switch is delivered without a tool kit. The tool kit is customer-supplied.

3 Installing the Switch

⚠ Caution

Before installing the switch, make sure that you have carefully read and met the requirements specified in Chapter 2.

3.1 Installation Flowchart

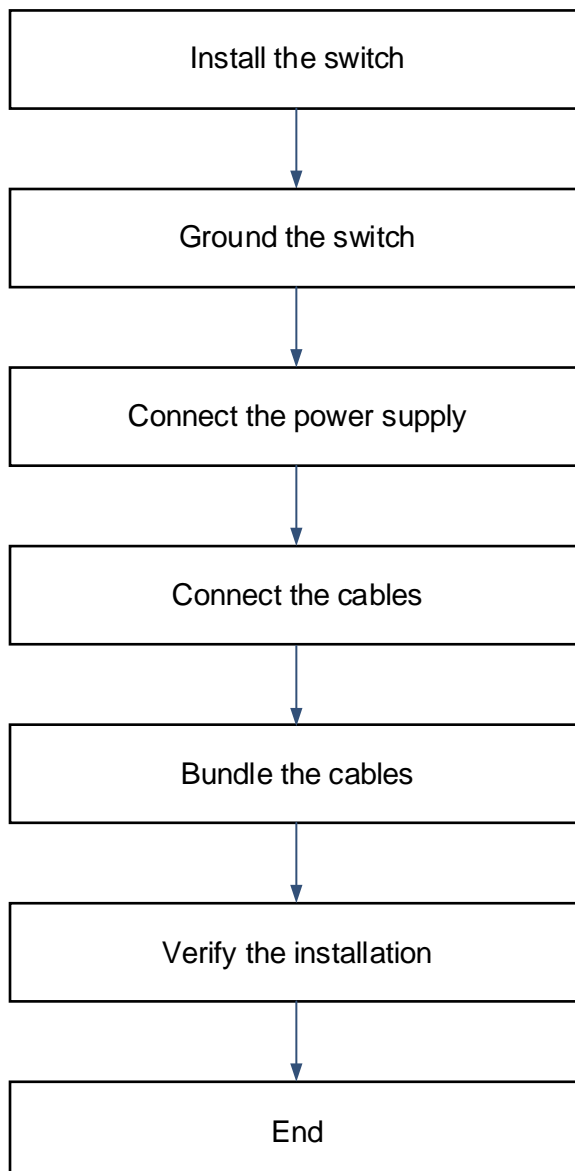

3.2 Before You Begin

- The installation site provides sufficient space for heat dissipation.
- The installation site meets the temperature and humidity requirements of the switch.
- The power supply is available in the installation site and meets requirement for current.
- The Ethernet cables have been deployed in the installation site.
- The selected power supply meets requirement for the system power.
- Find out the position of the emergency power switch before installation, so that the power switch can be cut off in case of accidents.

3.3 Installing the Switch

Pay attention to the following:

- Connect the power cords of different colors to the corresponding cable terminals.
- Ensure that the connector of the power cord is properly seated in the power port of the switch. After plugging the power cord into the switch, secure the power cord with power cord retention clip.
- Do not place anything on the top of the switch.
- Maintain a minimum clearance of 100 mm (3.94 in.) around the switch to ensure proper airflow. Do not stack switches.
- Keep the switch away from high-power radio launch pads, radar launch pads, and high-frequency large-current devices. Take electromagnetic shielding measures to minimize interference when necessary, for example, use shielded interface cables.
- Route Ethernet cables with a distance of 100 meters (328.08 ft) indoors. Take lightning protection measures if they need to be routed outdoors.

3.3.1 Installing the Switch in a Rack

The RG-NBS3100 switch meets the EIA standard and can be installed in a 19-inch rack. Take the following installation steps:

Step 1: Take screws out of the package. Attach one end of the mounting brackets to the switch by using screws.

Figure 3-1 Securing Mounting Brackets

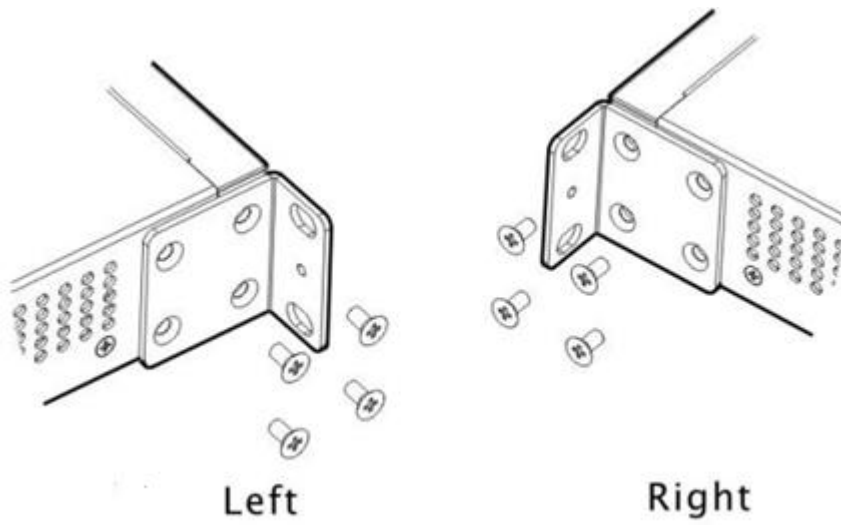

Step 2: Use M6 screws and cage nuts to secure the other end of the mounting brackets to square hole rack posts.

Figure 3-2 Installing Cage Nuts and Screws

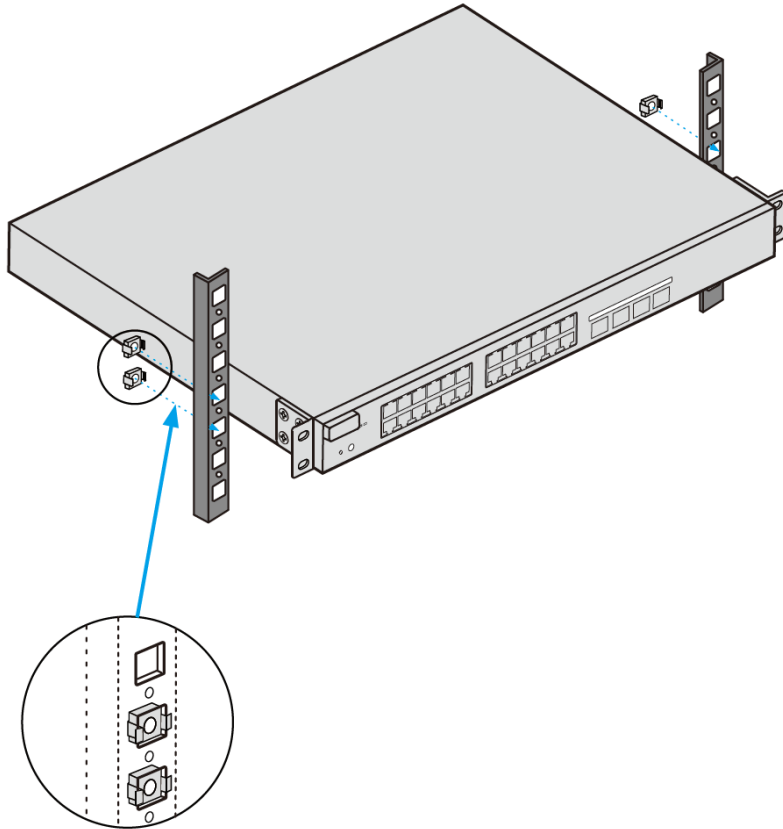
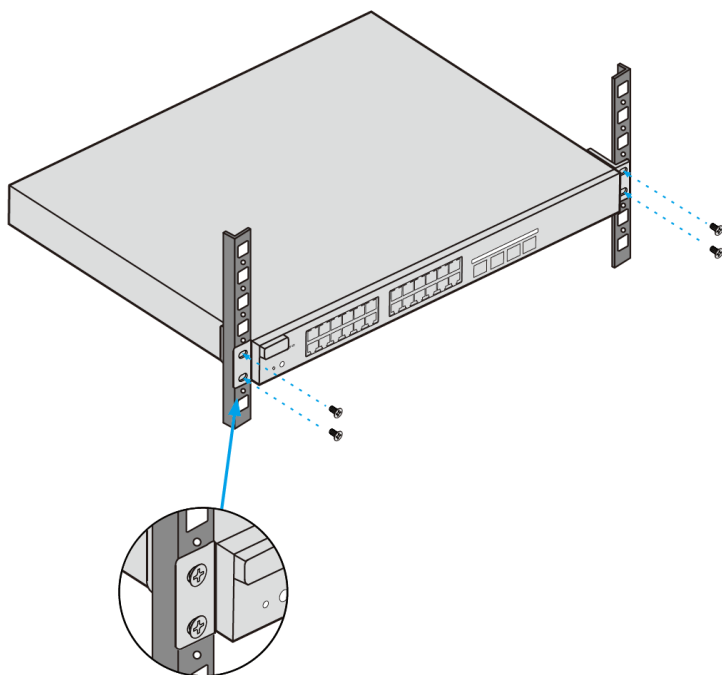

Figure 3-3 Tightening Screws



3.3.2 Installing the Switch on a Workbench

Step 1: Attach the four rubber feet to the four corners at the bottom of the switch.

Figure 3-4 Attaching Rubber Feet to the Bottom of the Switch

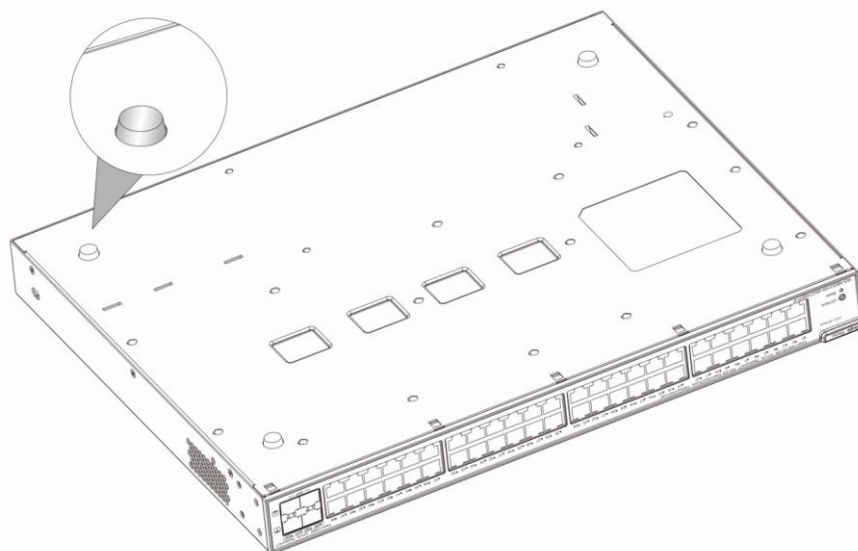

Step 2: Place the switch on a workbench and ensure adequate airflow around the switch.

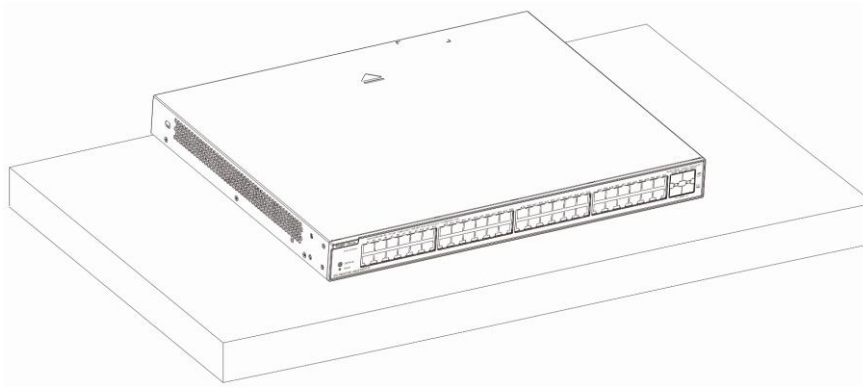
Figure 3-5 Installing the Switch on a Workbench

Note

The location where the switch is installed must be subject to movement restrictions.

3.4 Connecting the Switch to Earth Ground

The switch has a grounding stud on the rear panel. Connect the grounding stud to the grounding lug of the rack and then connect the grounding lug of the rack to the ground buss bar of the machine room.

Caution

- The sectional area of a grounding cable should be determined according to the possible maximum current. Grounding cables with good conductors should be used.
- Do not have bare wires exposed.
- The resistance between the chassis and ground should be less than 1 ohm.

Warning

- To avoid personal injury and device damage, connect the switch to earth ground properly. The grounding resistance between the chassis and the ground should be less than 1 ohm.
 - The O&M personnel should check whether the AC socket is reliably connected to the protective ground of the building. If not, the O&M personnel should use a protective earth conductor from the AC outlet protective earth terminal to the building protective earth.
 - The power socket should be installed near the device and easily accessible.
 - During the device installation, the ground connection must always be made first and disconnected last.
 - The cross-sectional area of a protective grounding cable should be at least 2.5 mm² (12 AWG).
-

3.5 Connecting Cables

Warning

Use the delivered power cords. Otherwise, security accidents may occur.

Precautions

- Make sure that the models of optical transceivers and optical cables match with SFP ports. The transmitting port on the local device should be connected to the receiving port on the peer device and vice versa.
- Avoid a small bend radius at the connector.

Steps

- (1) Connect the RJ45 connector of a twisted-pair cable to the Ethernet port on the switch, and the other end to a managed device or PC.
- (2) Plug the SMF and MMF optical fibers into the corresponding ports according to the panel identification, and distinguish the transmitting and receiving ends of the optical fibers.

3.6 Bundling Cables

Precautions

- Bundle the power cords and other cables in a visually pleasing way.
- Make sure that the fibers at the connectors have natural bends or bends of large radius.
- Do not bind fibers and twisted pair cables too tightly, as this may press the fibers and affect their service life and transmission performance.

Bundling Steps

- (1) Bind the drooping part of the optical cables and twisted pairs, and lead them to both sides of the chassis for convenience.
- (2) On both sides of the chassis, fasten the optical fibers and twisted pair cables to the cable management ring or cabling chute.
- (3) For the power cords, you should bind them closely along the bottom of the chassis, in a straight line wherever possible.

3.7 Verifying Installation

- Verify that the grounding cable is properly connected.
- Verify that the Ethernet cables and power cords are properly connected.
- Verify that the cables with a distance of 100 meters (328.08 feet) are managed indoors. If not, check whether the power supply and interfaces are protected from lightning strikes.
- Verify that there is a minimum clearance of 100 mm (3.94 in.) around the switch.

4 Verifying Operating Status

4.1 Setting up Configuration Environment

Connect the PC to the management port of the switch with an Ethernet cable.

Figure 4-1 Configuring Environment

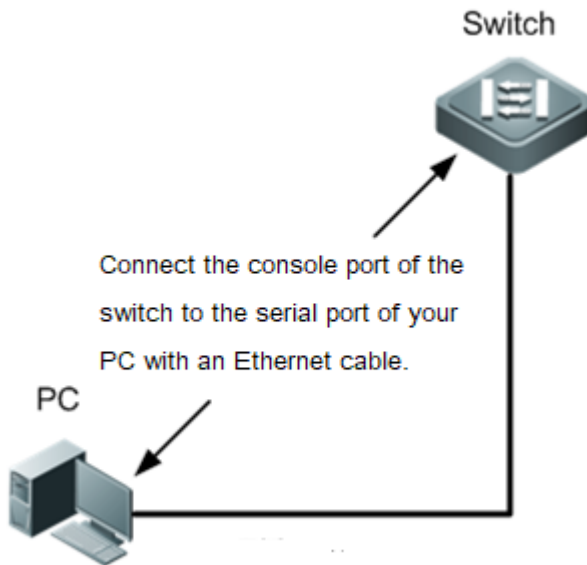

Connecting an Ethernet Cable

Plug the crystal head of the Ethernet cable into the network port of the PC.

Connect the RJ-45 end to any port of the switch.

Eweb-based Login

Step 1: Configure your PC with an IP address in the network of 10.44.77.XXX (Range: 1-255, excluding 200).

Step 2: Open a browser, enter 10.44.77.200 into the address bar of the browser and press Enter.

4.2 Powering on the Switch

4.2.1 Checklist Before Power-On

- The switch is connected to earth ground.
- The power cord is properly connected.
- The power voltage follows the requirement.
- The network port of the PC is properly connected to the console port of the switch. Parameters are set correctly.

4.2.2 Checklist After Power-On

- The LED statuses are normal.

- The main program is loaded properly.
- Service ports can forward data properly.

5 Common Troubleshooting

5.1 Troubleshooting Flowchart

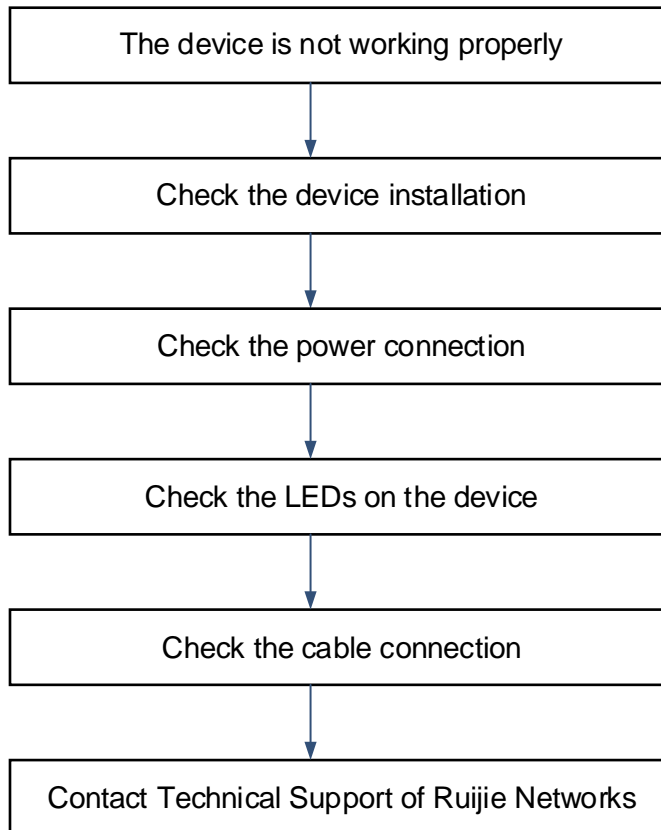

5.2 Common Faults

Symptom	Possible Cause	Suggested Action
The login password cannot be retrieved.	The login password is forgotten after being configured.	Press and hold the Reset button for over five seconds to reset your username and password.
The SYS indicator is off after the switch is powered on.	No power is supplied to the switch or the power cord is loose.	Check whether the power socket in the machine room is normal and whether the power cord connected to the switch is loose.
An RJ45 port is disconnected or a frame sending/receiving error occurs.	The twisted pair cable is not connected properly. The cable length exceeds 100 m (328.08 feet).	Replace the twisted pair cable. Use optical cables or connect to an intermediate switch for relay. Make sure that the port works in the same

	<p>The port is specially configured and does not use the same work mode as the interconnected switch.</p>	<p>mode as the interconnected switch.</p>
<p>An optical port cannot be connected.</p>	<p>The receiving and transmitting ends are connected incorrectly.</p> <p>The types of the interconnected optical transceivers do not match.</p> <p>The optical fiber type does not observe requirements.</p> <p>The length of the optical fiber length is beyond the allowed length marked on the optical transceiver.</p>	<p>Exchange the transmission and receiving ends of the optical fiber.</p> <p>Replace the optical transceiver with another one of the same type.</p> <p>Replace the optical fiber with a qualified one.</p> <p>Use an optical fiber with the required length.</p>

6 Appendix

6.1 Connectors and Media

- **1000BASE-T/100BASE-TX/10BASE-T Port**

1000BASE-T/100BASE-TX/10BASE-T is a 10/100/1000 Mbps port that supports auto negotiation and auto MDI/MDIX crossover.

Compliant with IEEE802.3ab, 1000BASE-T requires Category 5(5e) 100-ohm UTP or STP. SPT is recommended. 1000BASE-T supports a maximum distance reach of 100 meters (328.08 feet).

The 1000BASE-T port requires all four pairs of wires to be connected for data transmission. The following figure shows the connection of twisted pairs used by a 1000BASE-T port.

Figure 6-1 1000BASE-T Connection

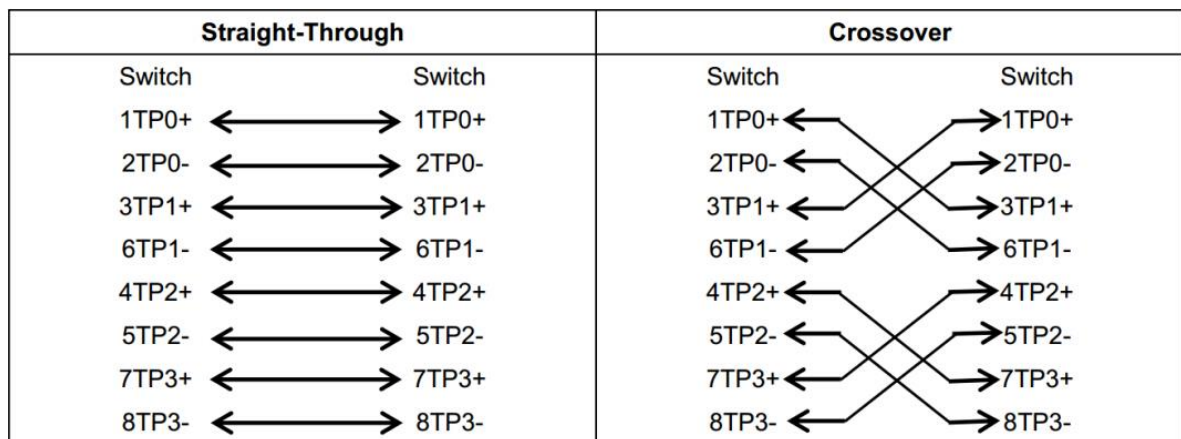

In addition to cables with the above-mentioned specifications, the 100BASE-TX/10BASE-T port can be connected through 100-ohm Category 3, 4 and 5 cables for 10Mbps or through 100-ohm Category 5 cables for 100Mbps. It supports a maximum distance reach of 100 meters (328.08 feet).

The following table shows 100BASE-TX/10BASE-T pin assignments.

Table 6-1 100BASE-TX/10BASE-T Pin Assignments

Pin	Socket	Plug
1	Input Receive Data+	Output Transmit Data+
2	Input Receive Data-	Output Transmit Data-
3	Output Transmit Data+	Input Receive Data+
6	Output Transmit Data-	Input Receive Data-
4,5,7,8	Not Used	Not Used

The following figure shows feasible connections of straight-through and crossover twisted-pair cables for 100BASE-TX/10BASE-T.

Figure 6-2 100BASE-TX/10BASE-T Twisted Pair Connections

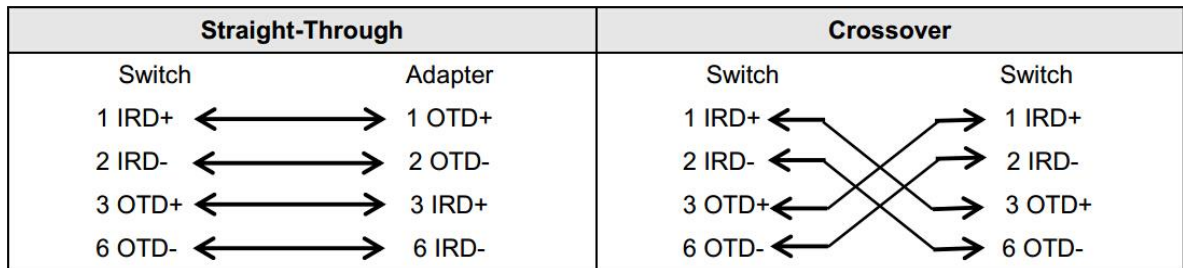

- **Fiber-Optic Cable Connection**

Choose single mode or multi-mode fibers according to the module types.

Figure 6-3 Fiber-Optic Cable Connection

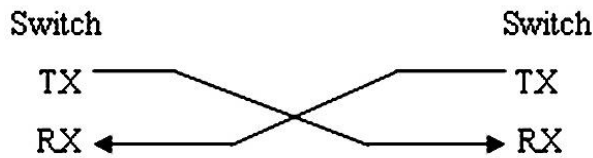

6.2 Mini-GBIC Modules

We provide appropriate SFP modules (Mini-GBIC modules) according to the port types. You can select the module to suit your specific needs. Besides, the Mini-GBIC-GT modules are also supported. The following models and technical specifications of some SFP modules are listed for your reference. For details about the technical specifications, see *Ruijie Transceiver Installation and Reference Guide*.

Table 6-2 Mini-GBIC (SFP) Models and Specifications

Model	Wavelength (nm)	Fiber Type	DDM (Yes/No)	Transmit Power (dBm)		Receive Power (dBm)	
				Min	Max	Min	Max
MINI-GBIC-SX-MM850	850	MMF	No	-9.5	-3	-17	0
MINI-GBIC-LX-SM1310	1310	SMF	No	-9.5	-3	-20	-3
GE-eSFP-SX-MM850	850	MMF	Yes	-9.5	-3	-17	0
GE-eSFP-LX-SM1310	1310	SMF	Yes	-9.5	-3	-20	-3
GE-SFP-LX-SM1310	1310	SMF	No	-9.5	-3	-20	-3
MINI-GBIC-LH40-SM1310	1310	SMF	Yes	-2	3	-22	-3
GE-SFP-SX-SM1310-BIDI	1310	MMF	No	-10	-5	-17	-3
GE-SFP-SX-SM1550-BIDI	1550	SMF	No	-10	-5	-17	-3
GE-SFP-LX20-SM1310-BIDI	1310TX/1550RX	SMF	Yes	-9	-3	-20	-3
GE-SFP-LX20-SM1550-BIDI	1550TX/1310RX	SMF	Yes	-9	-3	-20	-3
GE-SFP-LH40-SM1310-BIDI	1310TX/1550RX	SMF	Yes	-5	0	-24	-1
GE-SFP-LH40-SM1550-BIDI	1550TX/1310RX	SMF	Yes	-5	0	-24	-1
MINI-GBIC-ZX50-SM1550	1550	SMF	Yes	-5	0	-22	-3
MINI-GBIC-ZX80-SM1550	1550	SMF	Yes	0	4.7	-22	-3

MINI-GBIC-ZX100-SM1550	1550	SMF	Yes	0	5	-30	-9
GE-SFP-SX	850	MMF	No	-9.5	-3	-17	0
GE-SFP-LX	1310	SMF	No	-9.5	-3	-20	-3
SFP-MM850	850	MMF	No	-9.5	-3	-17	0
SFP-SM1310	1310	SMF	No	-9.5	-3	-20	-3

Table 6-3 1000Base-T SFP Copper Module

Standard	1000Base-TSFP Module	DDM Supported (Yes/No)
1000Base-T	Mini-GBIC-GT	No

Table 6-4 Cabling Specifications of SFP Modules

Model	Connector	Fiber Type	Core Size (um)	Max Cable Distance
MINI-GBIC-SX-MM850	LC	MMF	62.5/125	275 m
			50/125	550 m
MINI-GBIC-LX-SM1310	LC	SMF	9/125	10 km
GE-eSFP-SX-MM850	LC	MMF	62.5/125	275 m
			50/125	550 m
GE-eSFP-LX-SM1310	LC	SMF	9/125	10 km
GE-SFP-LX-SM1310	LC	SMF	9/125	10 km
MINI-GBIC-LH40-SM1310	LC	SMF	9/125	40 km
GE-SFP-SX-SM1310-BIDI	LC	MMF	50/125	500 m
GE-SFP-SX-SM1550-BIDI	LC	MMF	50/125	500 m
GE-SFP-LX20-SM1310-BIDI	LC	SMF	9/125	20 km
GE-SFP-LX20-SM1550-BIDI	LC	SMF	9/125	20 km
GE-SFP-LH40-SM1310-BIDI	LC	SMF	9/125	40 km
GE-SFP-LH40-SM1550-BIDI	LC	SMF	9/125	40 km
MINI-GBIC-ZX50-SM1550	LC	SMF	9/125	50 km

MINI-GBIC-ZX80-SM1550	LC	SMF	9/125	80 km
MINI-GBIC-ZX100-SM1550	LC	SMF	9/125	100 km
GE-SFP-SX	LC	MMF	62.5/125	275 m
			50/125	550 m
GE-SFP-LX	LC	SMF	9/125	10 km
Mini-GBIC-GT	RJ45 cable	Cat 5 (or better) twisted-pair cable		100 m

⚠ Caution

- For optical transceivers with a maximum cabling distance of over 40 km (including 40 km), install an optical attenuator to avoid overload when using short-distance SMFs.
- An optical transceiver is a laser transmitter. Do not look into the light source to prevent it from burning your eyes.
- To keep the optical transceiver clean, make sure that the unused ports remain capped.

Table 6-5 BIDI Transceiver Module Pairs

Speed/Distance	BIDI Transceiver Module Pairs
GE/500 m	GE-SFP-SX-SM1310-BIDI GE-SFP-SX-SM1550-BIDI
GE/20 km	GE-SFP-LX20-SM1310-BIDI GE-SFP-LX20-SM1550-BIDI
GE/40 km	GE-SFP-LH40-SM1310-BIDI GE-SFP-LH40-SM1550-BIDI
10GE/300 m	XG-SFP-SR-SM1270-BIDI XG-SFP-SR-SM1330-BIDI
10GE/10 km	XG-SFP-LR-SM1270-BIDI XG-SFP-LR-SM1330-BIDI

⚠ Caution

BIDI modules must be used in pairs. If GE-SFP-LX20-SM1310-BIDI is used at one end, then GE-SFP-LX20-SM1550-BIDI must be applied to the other end.

6.3 Lightning Protection

● Installing an AC Power Arrester (Lightning Resistance Socket)

When an AC power cord is introduced from outdoors and directly connected to the power port of the switch, the AC power port must be connected to an external lightning protection power strip to protect the switch against lightning strokes. The lightning resistance socket can be fixed on the rack, workbench, or wall in the machine room by using cable ties and screws. AC power enters the lightning protection power strip and then enters the switch.

Figure 6-4 Power Arrester

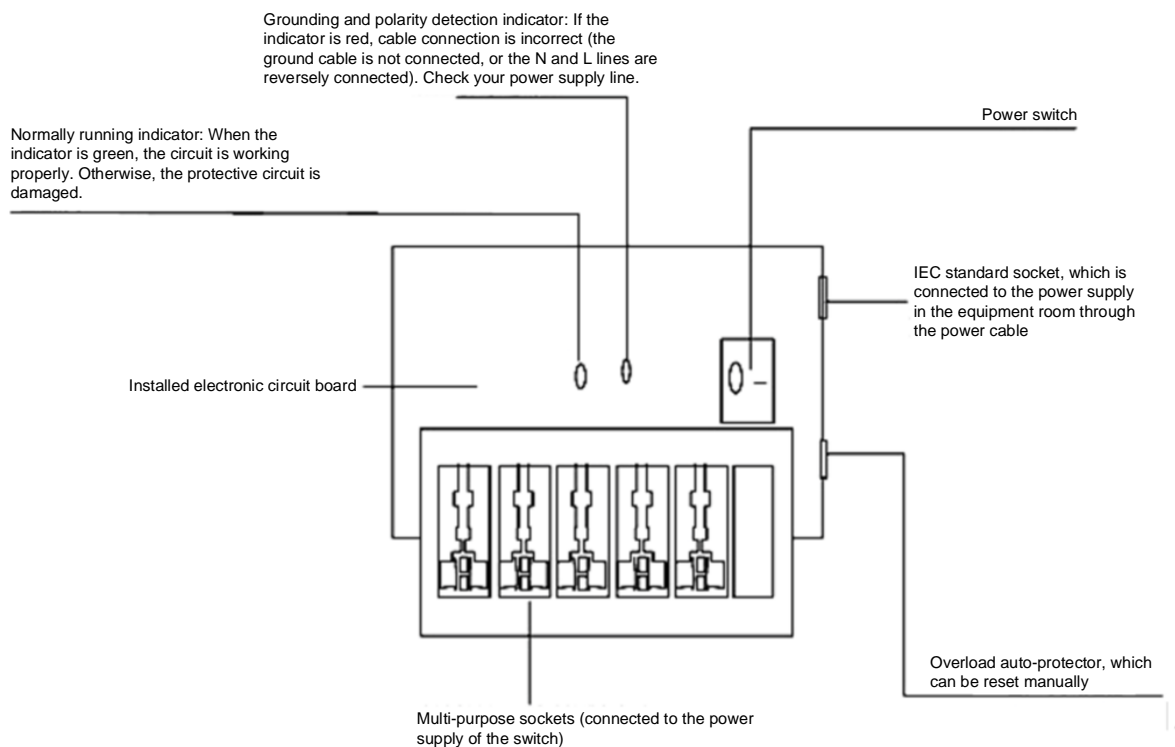

Note

The power arrester is not delivered with the switch. Please purchase it based on actual requirements.

Precautions:

- Make sure that the PE terminal of the power arrester is well grounded.
- After the AC power plug of the switch is connected to the socket of the power arrester (lightning resistance socket), the lightning protection function is implemented only if the RUN indicator is green and the ALARM indicator is OFF.
- If the ALARM indicator on the power arrester is red, check whether it is caused by poor grounding connection or by the reversed connection of the Null and Live lines. The detection method is as follows: Use a multimeter to measure the polarity of the power socket for the arrester when the indicator is red. If the N line is on the left and the L line is on the right (facing the socket), the arrester's PE terminal is not grounded. If not, the polarity of the arrester power cord should be reversed. In this case, you should open the power arrester and

rectify the polarity of the connection. If the indicator is still red, the arrester's PE terminal is not grounded.

● Installing the Ethernet Port Arrester

Connect an Ethernet port arrester to the switch to prevent the damage by lightning before connecting an outdoor network cable to the switch.

Tools: Phillips screwdrivers or flat-head screwdriver, multimeter, and diagonal pliers

Installation steps:

- (1) Tear one side of the protective paper for the double-sided adhesive tape and paste the tape to the enclosure of the Ethernet port arrester. Tear the other side of the protective paper for the double-sided adhesive tape and paste the Ethernet port arrester to the switch enclosure. The paste position for the Ethernet port arrester should be as close to the grounding lug of the switch as possible.
- (2) According to the distance between the switch grounding lug and the Ethernet port arrester, cut the grounding cable for the Ethernet port arrester and firmly crimp the grounding cable to the grounding lug of the switch.
- (3) Use a multimeter to check whether the grounding cable for the arrester is in good contact with the grounding lug and the enclosure of the switch.
- (4) Connect the arrester by using an adapter cable (note that the external network cable is connected to the IN end, while the adapter cable connected to the switch is connected to the OUT end) and check whether the service module LED is normal.
- (5) Use a nylon cable tie to bind the power cords.

Figure 6-5 Installation of the Ethernet Port Arrester

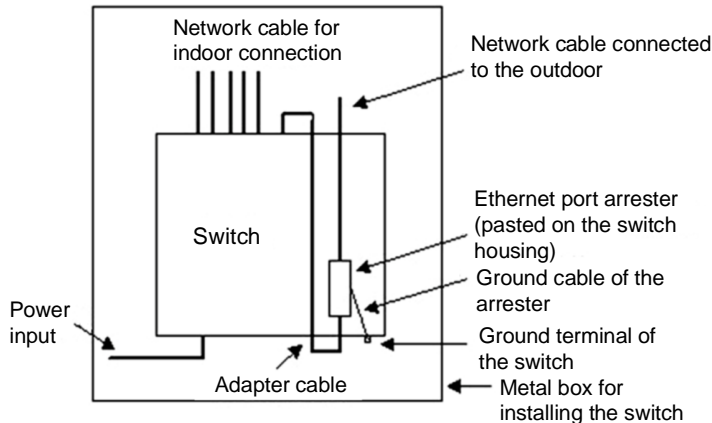

i Note

- The Ethernet port arrester is only for the 10/100 Mbps copper ports with an RJ-45 connector.
- The Ethernet port arrester is not delivered with the switch. Please purchase it based on actual requirements.

Pay attention to the following situations during the actual installation to avoid influencing the performance of the Ethernet port arrester:

- Reversed installation direction of the arrester. Connect the external network cable to the "IN" end and connect the Ethernet port of the switch to the "OUT" end.
- Poor grounding of the arrester. The grounding cable of the arrester should be as short as possible to ensure that it is in good contact with the grounding lug of the switch. Use a multimeter to confirm the contact condition

after grounding.

Incomplete arrester installation. If there is more than one port connected to the peer device on the switch, arresters need to be installed on all connection ports for the purpose of lightning protection.

6.4 Cabling Recommendations

When the switch is installed in a standard 19-inch rack, secure the cables around the cable management brackets. Adopt top cabling or bottom cabling according to the actual situation in the machine room. All adapted connectors should be placed at the bottom of the rack in an orderly manner instead of outside the rack that is easy to touch. Power cords are routed beside the rack. Top cabling or bottom cabling is adopted according to the actual situation in the machine room, such as the positions of the DC power distribution box, AC socket, or lightning protection box.

6.4.1 Requirement for the Minimum Bend Radius of an Ethernet Cable

- The bend radius of a fixed power cord, Ethernet cable, or flat cable should be over five times greater than their respective diameters. The bend radius of these cables that are often bent or plugged should be over seven times greater than their respective diameters.
- The bend radius of a fixed common coaxial cable should be over seven times greater than its diameter. The bend radius of the common coaxial cable that is often bent or plugged should be over 10 times greater than its diameter.
- The bend radius of a fixed high-speed cable (such as SFP+ cable) should be over five times greater than its diameter. The bend radius of the fixed high-speed cable that is often bent or plugged should be over 10 times greater than its diameter.

6.4.2 Requirement for the Minimum Bend Radius of a Fiber-Optic Cable

- The diameter of a fiber tray to hold fibers should be over 25 times greater than the diameter of the fiber.
- When an optical fiber is moved, the bend radius of the fiber should be over 20 times greater than the diameter of the fiber.
- During cabling of an optical fiber, the bend radius of the fiber should be over 10 times greater than the diameter of the fiber.

6.4.3 Precautions for Bundling up Cables

- Before cables are bundled, mark labels and stick the labels to cables wherever appropriate.
- Cables should be neatly and properly bundled in the rack without twisting or bending.

Figure 6-6 Binding Cables (1)

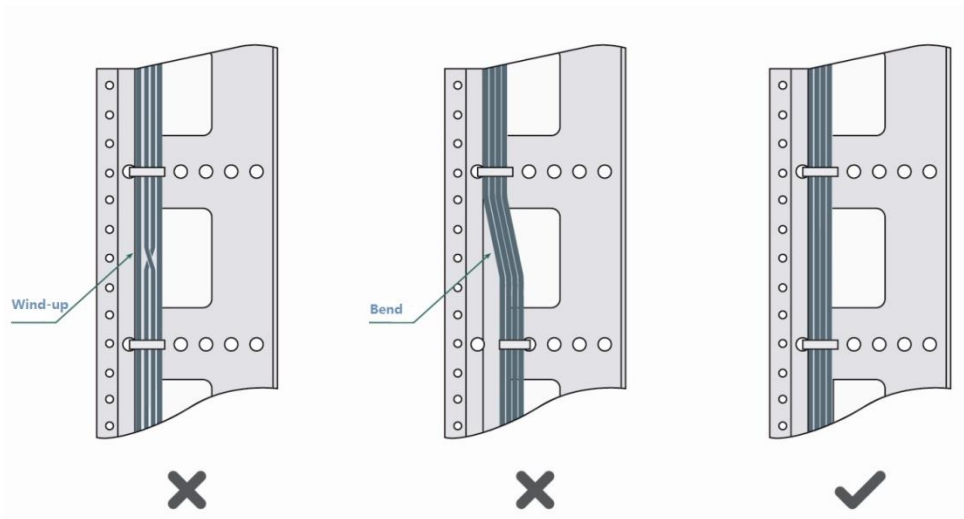

- Cables of different types (such as power cords, signal cables, and grounding cables) should be separated in cabling and bundling. Mixed bundling is disallowed. When they are close to each other, you are advised to adopt crossover cabling. In the case of parallel cabling, maintain a minimum distance of 30 mm (1.18 in.) between power cords and signal cables.
- The cable management brackets and cabling troughs inside and outside the rack should be smooth without sharp corners.
- The metal hole traversed by cables should have a smooth and fully rounding surface or an insulated lining.
- Use cable ties to bundle up cables properly. Please do not connect two or more cable ties to bundle up cables.
- After bundling up cables with cable ties, cut off the remaining part. The cut should be smooth and trim without sharp corners.

Figure 6-7 Binding Cables (2)

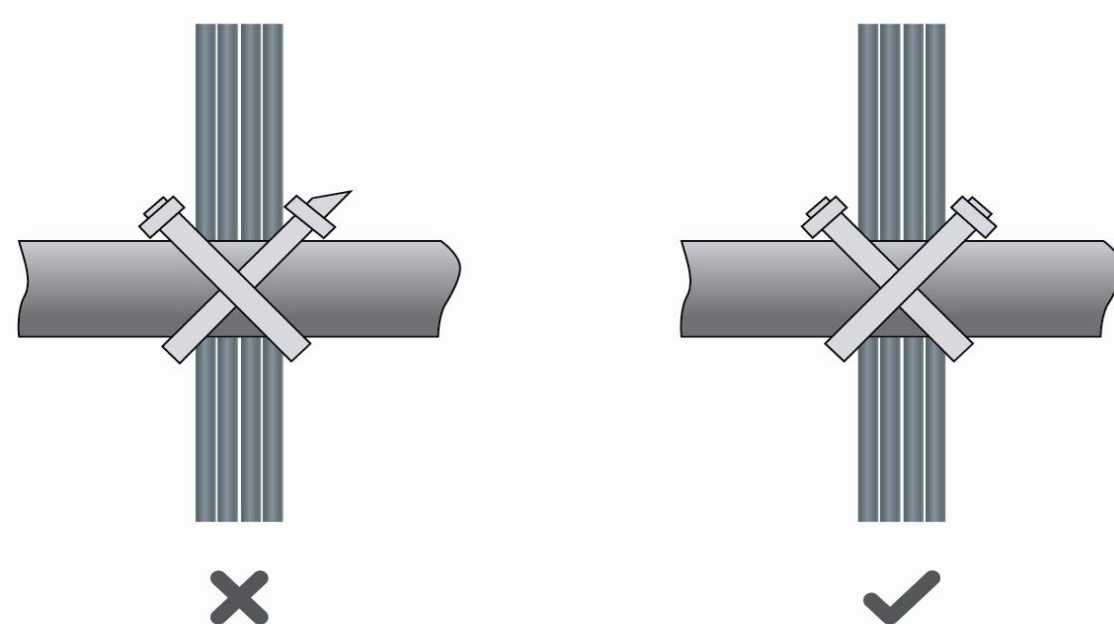

- When cables need to be bent, please bundle them up but do not tie cable ties within the bend. Otherwise,

stress may be generated on the cables and causes the wires inside to break.

Figure 6-8 Binding Cables (3)

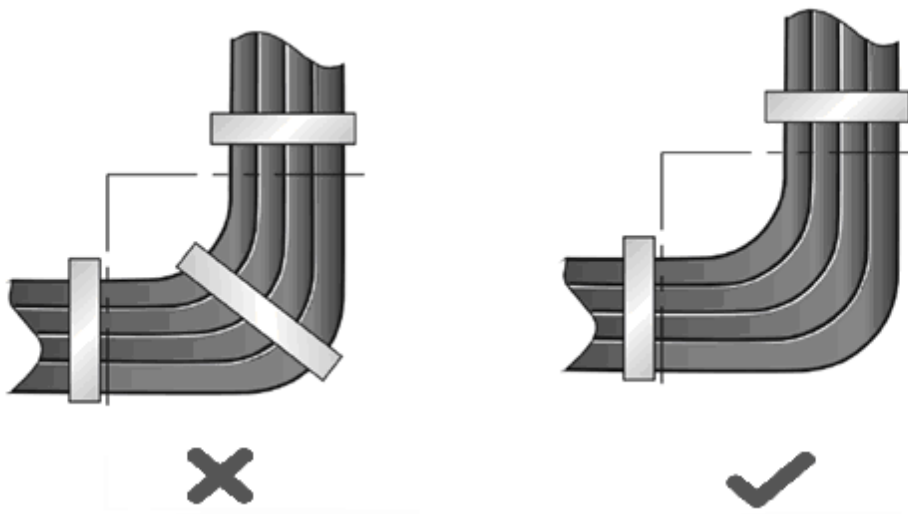

- Cables not to be assembled or remaining parts of cables should be folded and placed in a proper position of the rack or cable trough. The proper position refers to a position that does not affect device running or damage the switch or cable.
- Do not bind power cords to the guide rails of moving parts.
- The power cords connecting moving parts such as door grounding cables should be reserved with some excess after being assembled. This can avoid tension or stress on power cords. After the moving part is installed, the remaining cable part should not touch heat sources, sharp corners, or sharp edges. If heat sources cannot be avoided, high-temperature cables should be used.
- When screw threads are used to fasten a cable terminal, the bolt or screw must be tightly fastened, and measures should be taken to retain the terminal.

Figure 6-9 Cable Fastening

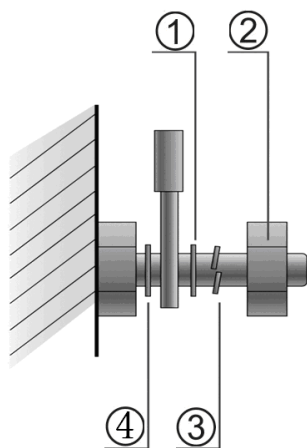

- | | |
|---------------|-----------------|
| ① Flat washer | ③ Spring washer |
| ② Nut | ④ Flat washer |

- Hard power cords should be fastened in the terminal connection area to prevent stress on terminal connection and cable.
- Do not use self-tapping screws to fasten terminals.
- Power cords of the same type and in the same cabling direction should be bundled up into cable bunches, with cables in cable bunches clean and straight.
- Bundle up cables by using cable ties.

Cable Bunch Diameter (mm)	Binding Spacing (mm)
10 mm (0.39 in.)	80 mm to 150 mm (3.15 in. to 5.91 in.)
10 mm to 30 mm (0.39 in. to 1.18 in.)	150 mm to 200 mm (5.91 in. to 7.87 in.)
30 mm (0.39 in.)	200 mm to 300 mm (7.87 in. to 11.81 in.)

- No knot is allowed in cabling or bundling.
- For wiring terminal blocks (such as circuit breakers) with cord end terminals, the metal part of the cord end terminal should not be exposed outside the terminal block when assembled.

6.5 Site Selection

- The machine room should be at least 5 km (3.11 miles) away from heavy pollution sources, such as the smelter works, coal mine, and thermal power plant. The machine room should be at least 3.7 km (2.30 miles) away from medium pollution sources, such as the chemical factory, rubber factory, and electroplating factory. The machine room should be at least 2 km (1.24 miles) away from light pollution sources, such as the food factory and leather plant. If the pollution source is unavoidable, the machine room should be located on the windward side of the pollution source perennially with advanced protection.
- The machine room should be at least 3.7 km (2.30 miles) away from the sea or salt lake. Otherwise, the machine room must be sealed, with air conditioner installed for temperature control. Saline soil cannot be used for construction. Otherwise, you should select devices with advanced protection against severe environment.
- Do not build the machine room in the proximity of livestock farms. Otherwise, the machine room should be located on the windward side of the pollution source perennially. The previous livestock house or fertilizer warehouse cannot be used as the machine room.
- The machine room should be firm enough to withstand severe weather conditions such as windstorm and heavy rain as well as away from dust. If the dust is unavoidable, keep the door and window away from the pollution source.
- The machine room should be away from the residential area. Otherwise, the machine room should meet the construction standard in terms of noise.
- Make sure the air vent of the machine room is away from the sewage pipe, septic tank, and sewage treatment tank. Keep the machine room under positive pressure to prevent corrosive gas from entering the machine room to corrode components and circuit boards.
- Keep the machine room away from industrial boiler and heating boiler.
- The machine room should be on the second floor. Otherwise, the machine room floor should be 600 mm (23.62 in.) higher than the highest flood level ever recorded.
- Make sure there are no cracks or holes in the wall and floor. If there are cable entries in the wall or window, take proper sealing measures. Ensure that the wall is flat, wear-resistant, and dust-free, which should be up to the standard for flame retarding, soundproofing, heat absorption, dust reduction, and electromagnetic shielding.
- Keep the door and the window closed to make the machine room sealed.
- The steel door is recommended for soundproofing.
- Sulfur-containing materials are forbidden.
- Keep the air conditioner from blowing wind straight toward the device or blowing water drops from the window or air vent toward the device.